

TRANSFORMATORI MONOFAZNI

70mm

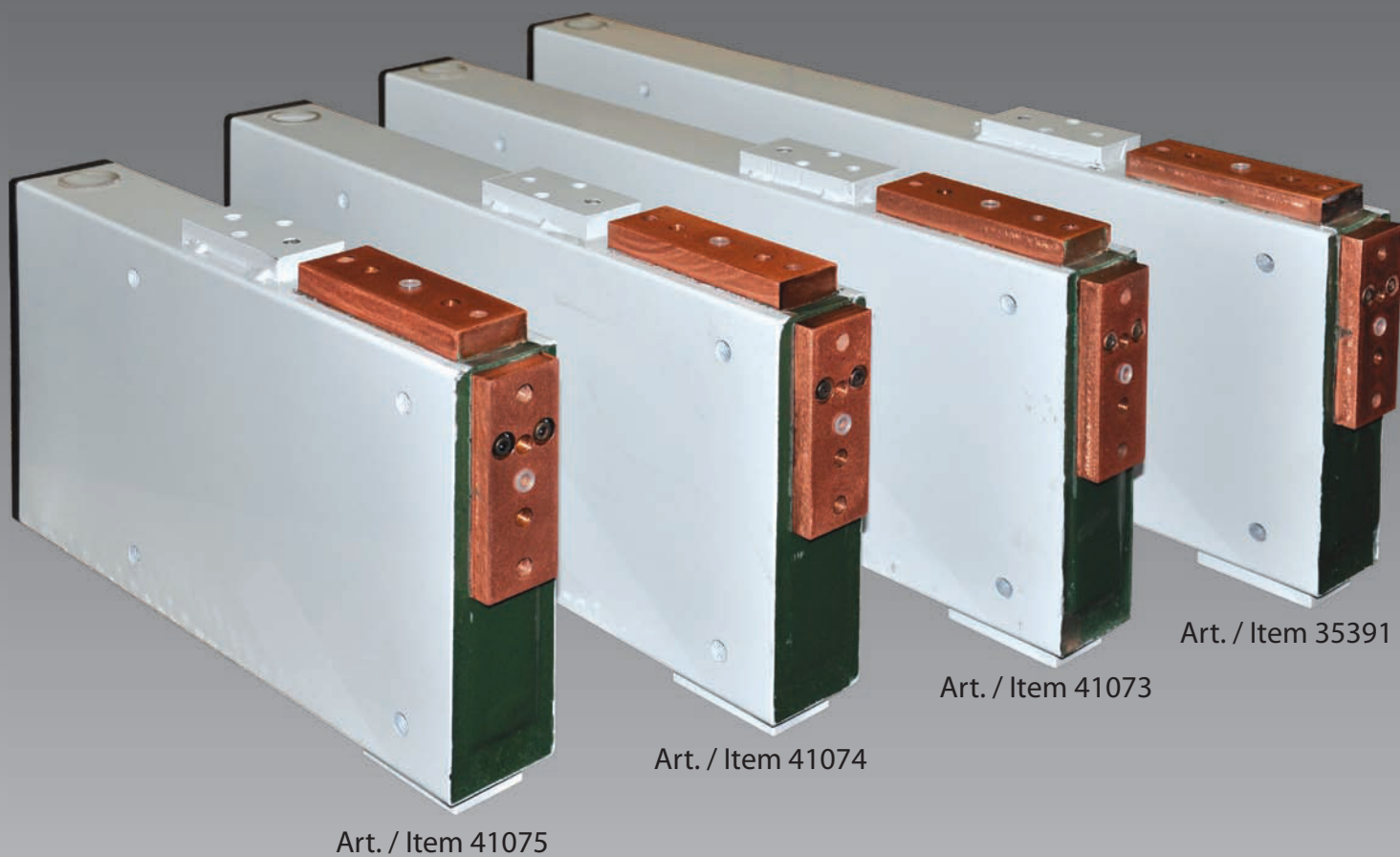

Art. / Item 41075

Art. / Item 41074

Art. / Item 41073

Art. / Item 35391

ALATIS THERM d.o.o

Koče Kapetana 25, 35230 Čuprija, Srbija
tel/fax : +381 (0) 35 8471-196
mob1/2 : +381 (0) 65 2771-802 / +381 (0) 65 8410-651



ART.	kVA	U ₁ /Freq Volt/Hz	I ₁ 100% A	V ₂₀ Volt				I ₂ 100% kA	Vcc %	H ₂ O l/min	L1	L2	D	PG	COLORE	kg	ISO
				1	2	3	4										
41075	32	*400/50	-	3,05	-	-	-	7,37	-	4	755	560	M10	29	ZINCATO - GALVANIZED GALVANISE - GALVANIZADO GALVANISIERT	36	5826
41074	45	*400/50	-	4,65	-	-	-	6,84	-	4	655	460	M10	29	ZINCATO - GALVANIZED GALVANISE - GALVANIZADO GALVANISIERT	47	5826
41073	63	*400/50	-	6,45	-	-	-	6,90	-	4	555	360	M10	29	ZINCATO - GALVANIZED GALVANISE - GALVANIZADO GALVANISIERT	57	5826
35391	100	*400/50	-	8,00	-	-	-	8,80	-	4	455	260	M10	29	ZINCATO - GALVANIZED GALVANISE - GALVANIZADO GALVANISIERT	67,5	5826

* Altre tensioni e frequenze a richiesta. - * Different voltages and frequencies on request. - * Voltages et tensions différents sur demande. - * Andere Spannungen und Frequenzen auf Anfrage. - * Otras tensiones y frecuencias bajo demanda.

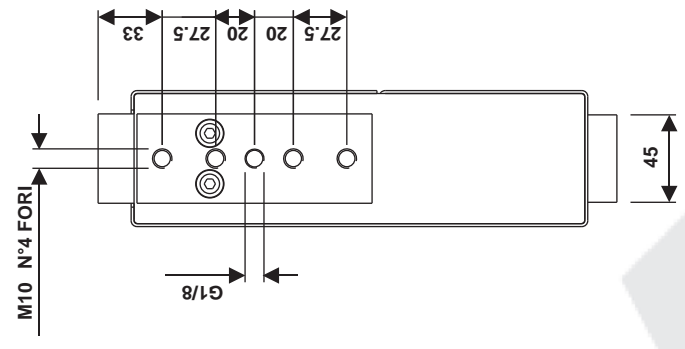
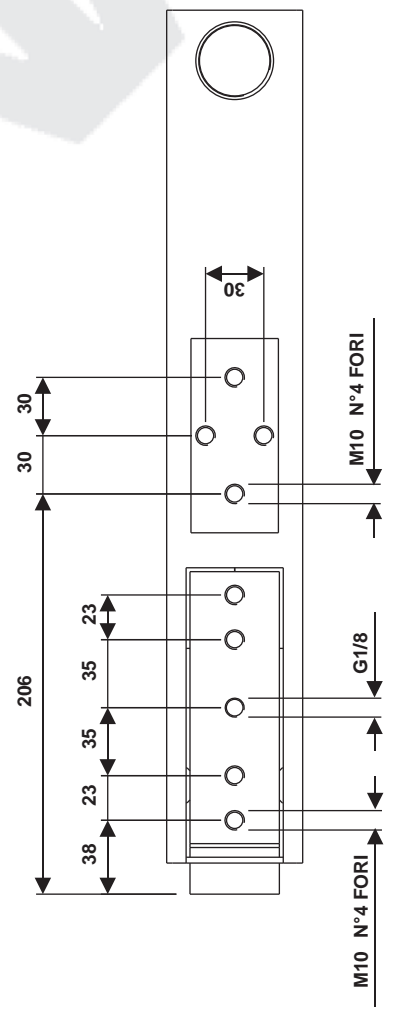
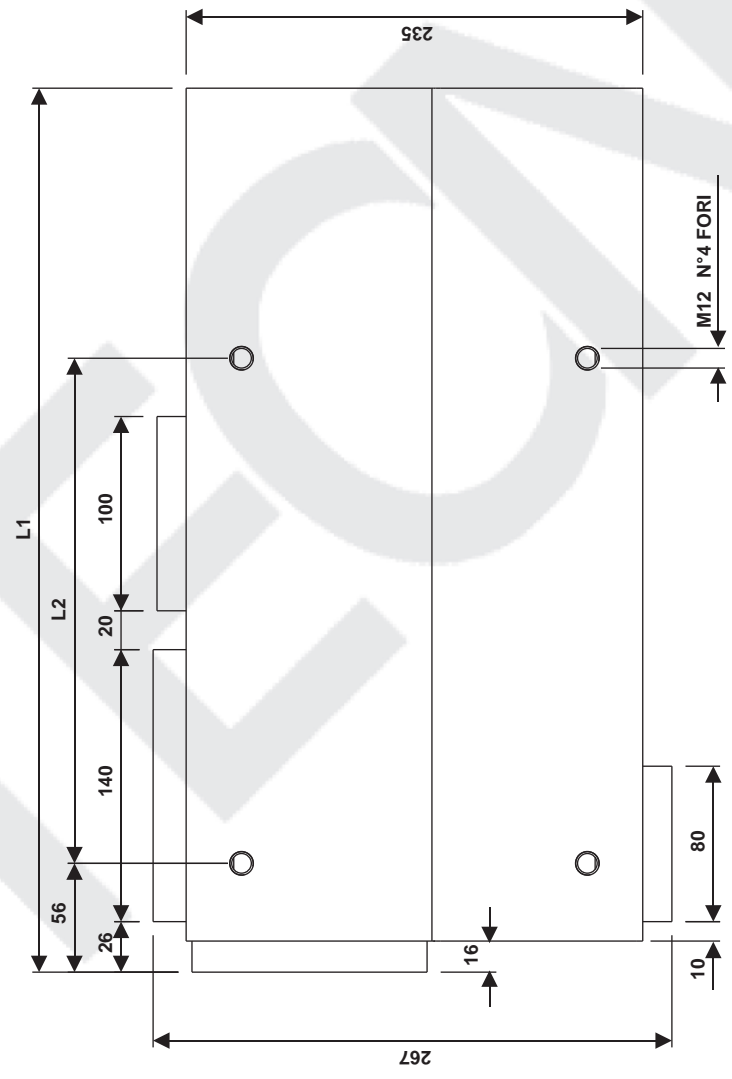
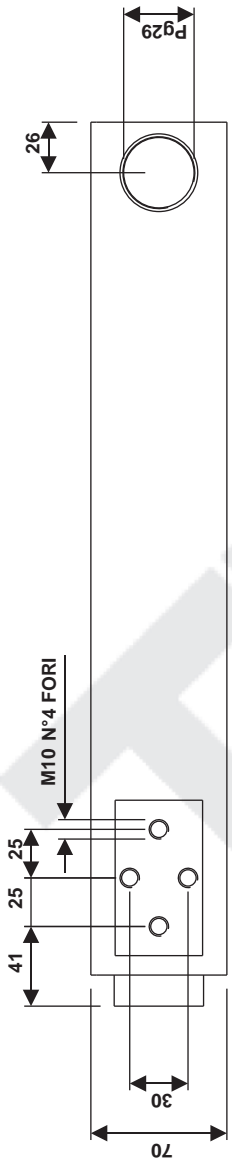

TECNA[®]

ALATIS THERM d.o.o

Koče Kapetana 25 , 35230 Čuprija , Srbija
tel/fax : +381 (0) 35 8471-196
mob1/2 : +381 (0) 65 2771-802 / +381 (0) 65 8410-651

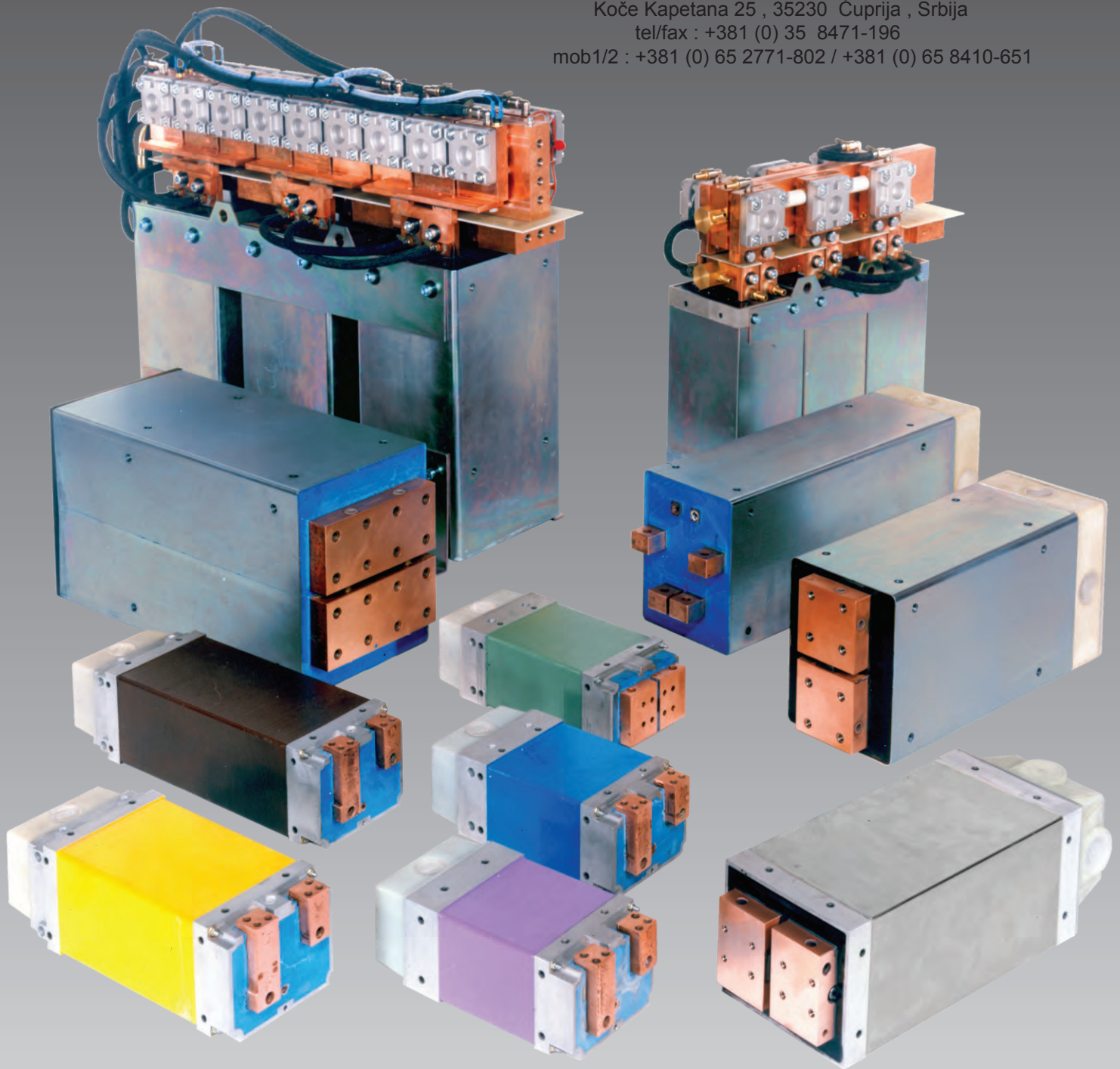

GENERAL CATALOGUE

Transformers

TECNA®

**SINGLE-PHASE
TRANSFORMERS
H-ROBOT TYPE
ISO 5826
32 ÷ 36 kVA**

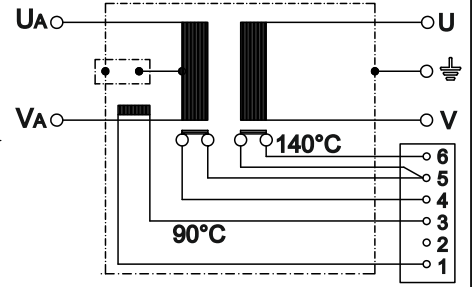
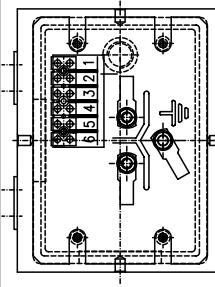
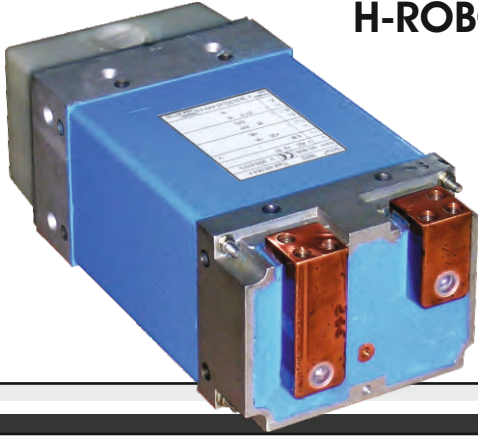

○ ○ SECONDARIO ISOLATO

○ ○ SECONDARIO A MASSA ↓

CONNESS.	DESCRIZIONE CONNESS.
1-3	V=150mV/kA/1000ohm
4-5	TERMOSTATO 90°C
5-6	TERMOSTATO 140°C
4-6	TERMOSTATI N.C.

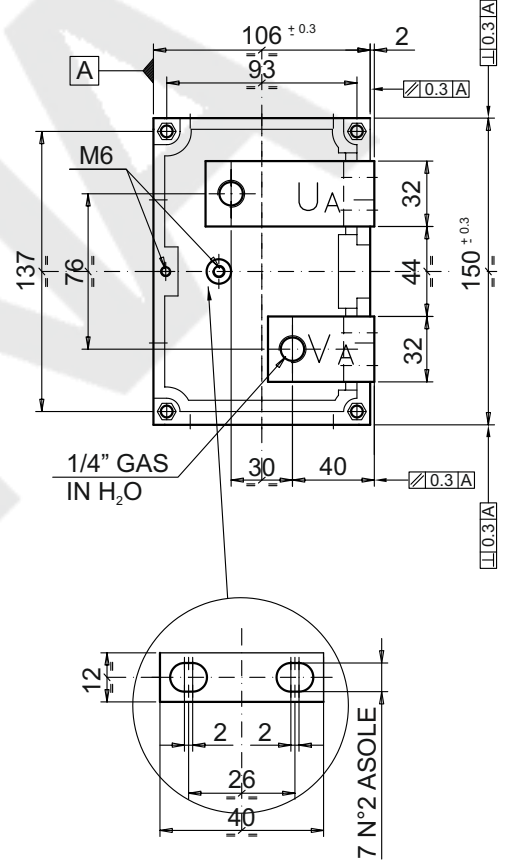
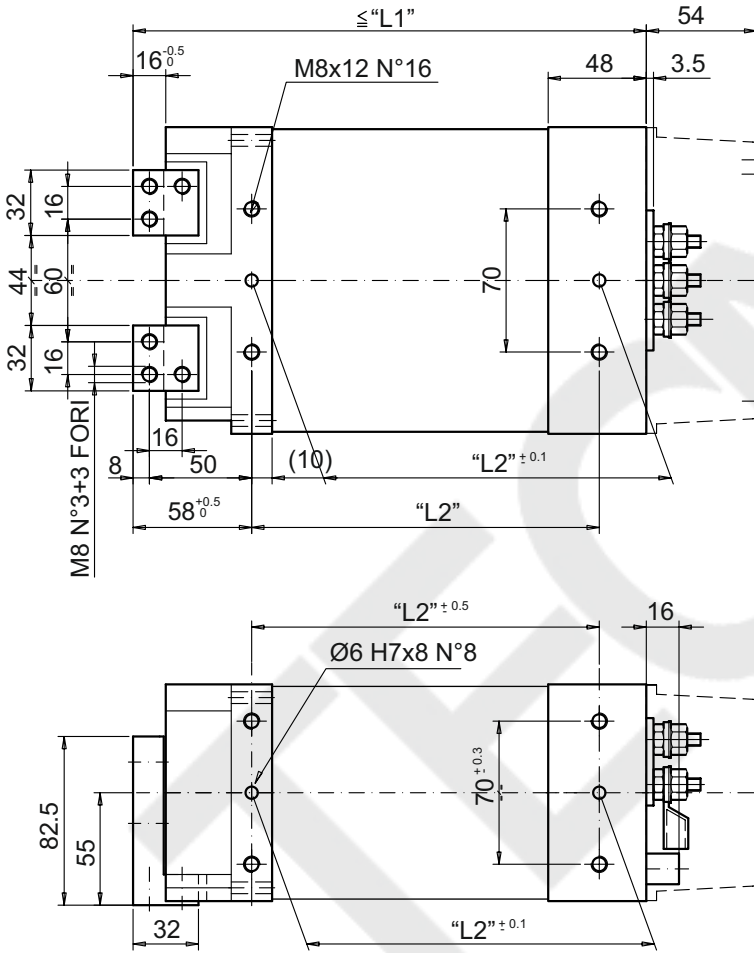

ITEM	kVA	U ₁ /Freq Volt/Hz	I ₁ 100% A	V ₂₀ Volt				I ₂ 100% kA	Vcc %	H ₂ O l/min	L1	L2	D	PG	COLOR	kg	ISO
				1	2	3	4										
H-ROBOT-39202	36	*400/50	63	6,4	-	-	-	4	-	4	260	170	M6	21	RAL 5015	23	10656
H-ROBOT-32526	32	*400/50	56	5,6	-	-	-	4	-	4	248	170	M6	21	RAL 4005	21	-

* Different voltages and frequencies on request.

TECNA S.p.A. Specifications subject to change without notice.

TECNA®

**SINGLE-PHASE
TRANSFORMERS
J-ROBOT TYPE
ISO 5826
54 ÷ 103 kVA**

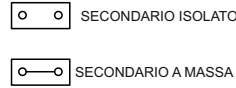
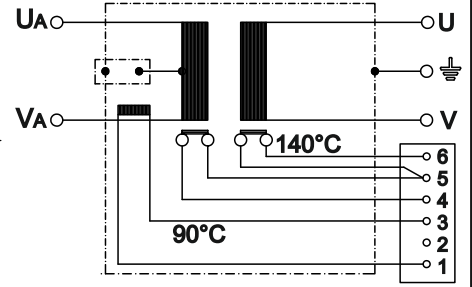
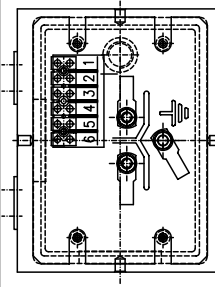
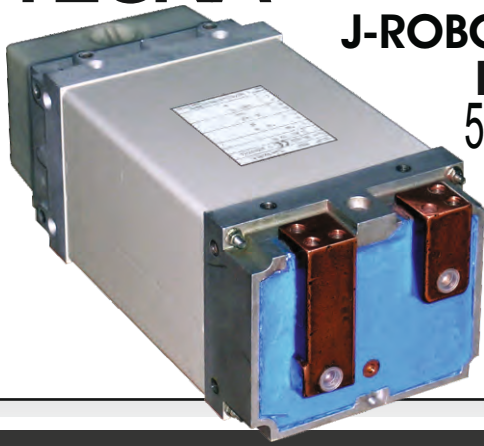

CONNEX.	DESCRIZIONE CONNEX.
1-3	V=150mV/kA/1000ohm
4-5	TERMOSTATO 90°C
5-6	TERMOSTATO 140°C
4-6	TERMOSTATI N.C.

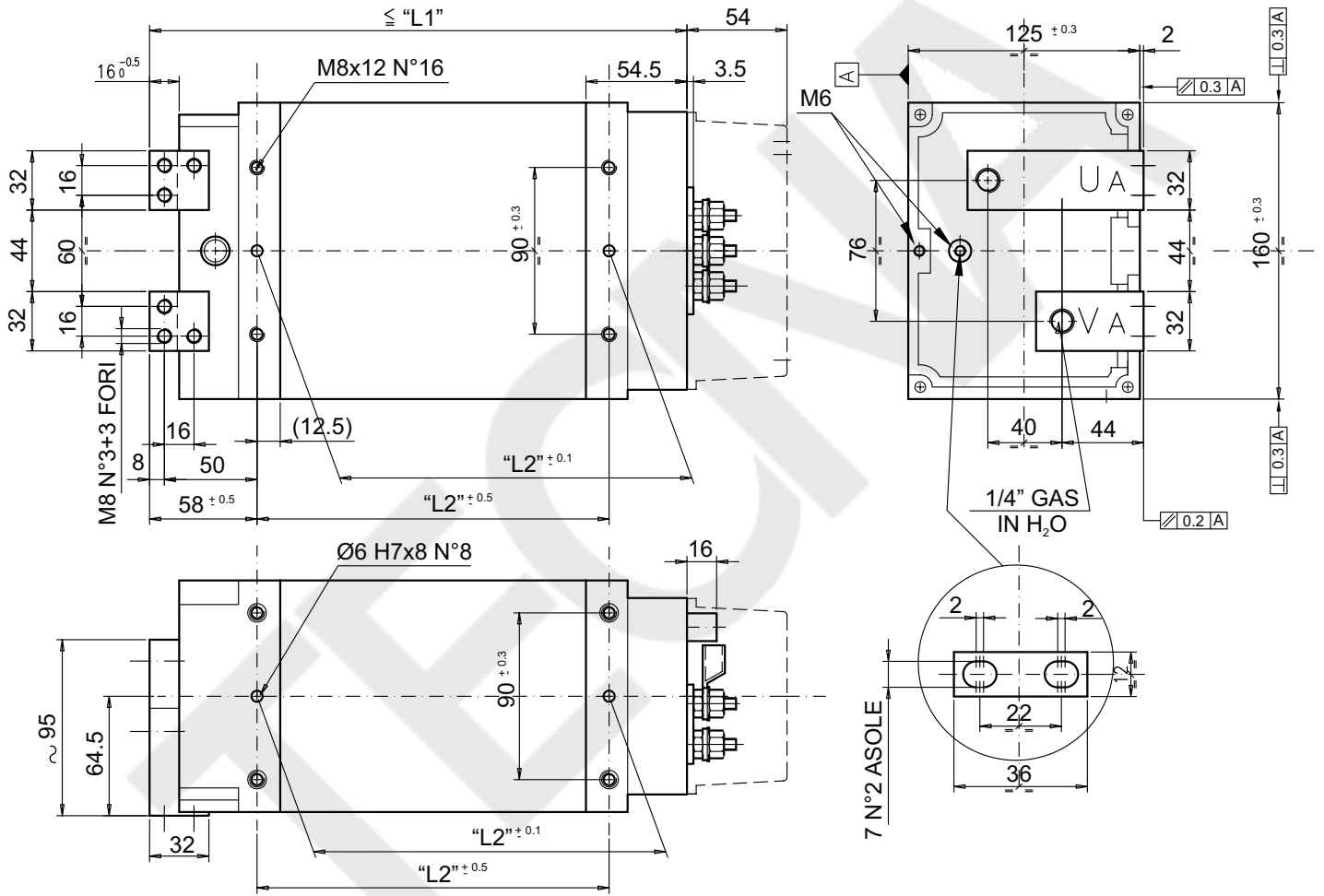

ITEM	kVA	U ₁ /Freq Volt/Hz	I ₁ 100% A	V ₂₀ Volt				I ₂ 100% kA	Vcc %	H ₂ O l/min	L1	L2	D	PG	COLOR	kg	ISO
				1	2	3	4										
J-ROBOT-33009	103	*400/50	182	13,5	-	-	-	5,4	-	4	442	350	M8	21/36	RAL 8016	54	10656
J-ROBOT-39067**	75	*400/50	132	10	-	-	-	5,4	-	4	360	260	M8	21/36	RAL 1023	41	10656
J-ROBOT-39201**	60	*400/50	106	8	-	-	-	5,4	-	4	308	230	M8	21/36	RAL 7032	35	10656
J-ROBOT-39200**	54	*400/50	95	7,1	-	-	-	5,4	-	4	290	190	M8	21/36	RAL 6011	32	10656
J-ROBOT-34235	48	*400/50	-	6,4	-	-	-	5,4	-	4	270	190	M8	21/36	RAL 5015	29	10656

* Different voltages and frequencies on request.

** Upon demand, the transformers are supplied in compliance with CNOMO E34.73.460.N

TECNA S.p.A. Specifications subject to change without notice.

TECNA®

SINGLE-PHASE TRANSFORMERS

ISO 5826 12 ÷ 25 kVA

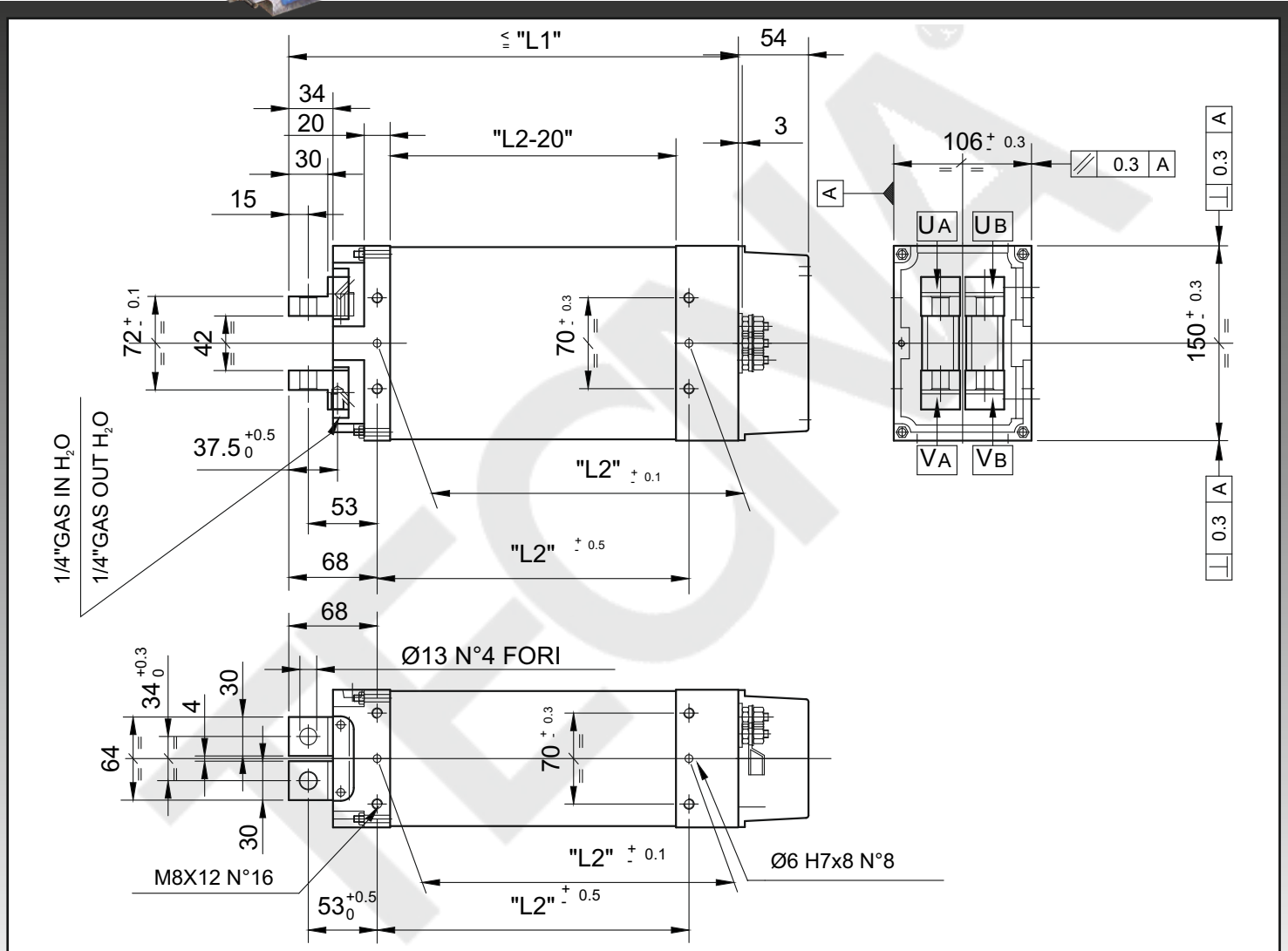
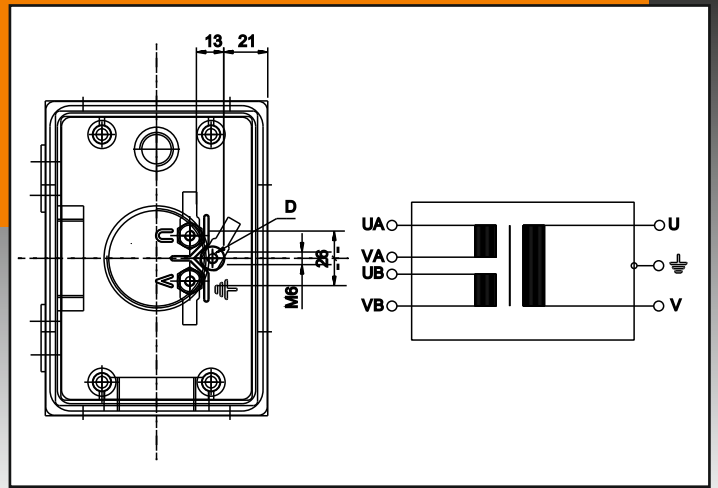
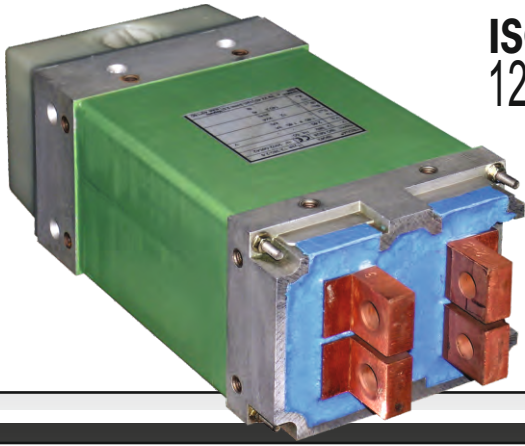

ITEM	kVA	U ₁ /Freq Volt/Hz	I ₁ 100% A	V ₂₀ Volt				I ₂ 100% kA	Vcc %	H ₂ O l/min	L1	L2	D	PG	COLOR	kg	ISO
				1	2	3	4										
39063	25	*380/50	47	3,9	-	-	-	2,3+2,3	-	4	346	240	M6	21	RAL 6011	28	-
39062	12	*380/50	22	2,6	-	-	-	1,6+1,6	-	2	286	180	M6	21	RAL 6011	22	-

* Different voltages and frequencies on request.

TECNA S.p.A. Specifications subject to change without notice.

TECNA®

SINGLE-PHASE TRANSFORMERS

ISO 5826 32 ÷ 36 kVA

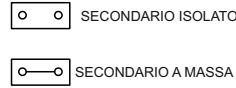
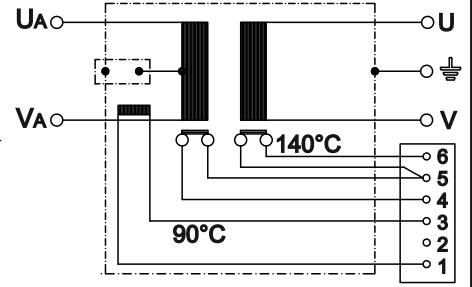
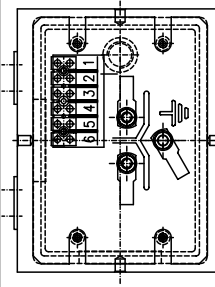
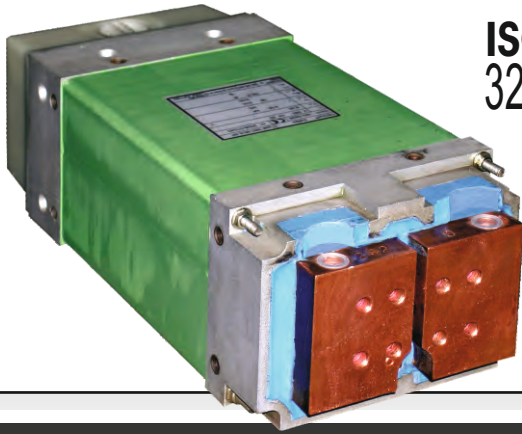

CONNESS.	DESCRIZIONE CONNESS.
1-3	V=150mV/kA/1000ohm
4-5	TERMOSTATO 90°C
5-6	TERMOSTATO 140°C
4-6	TERMOSTATI N.C.

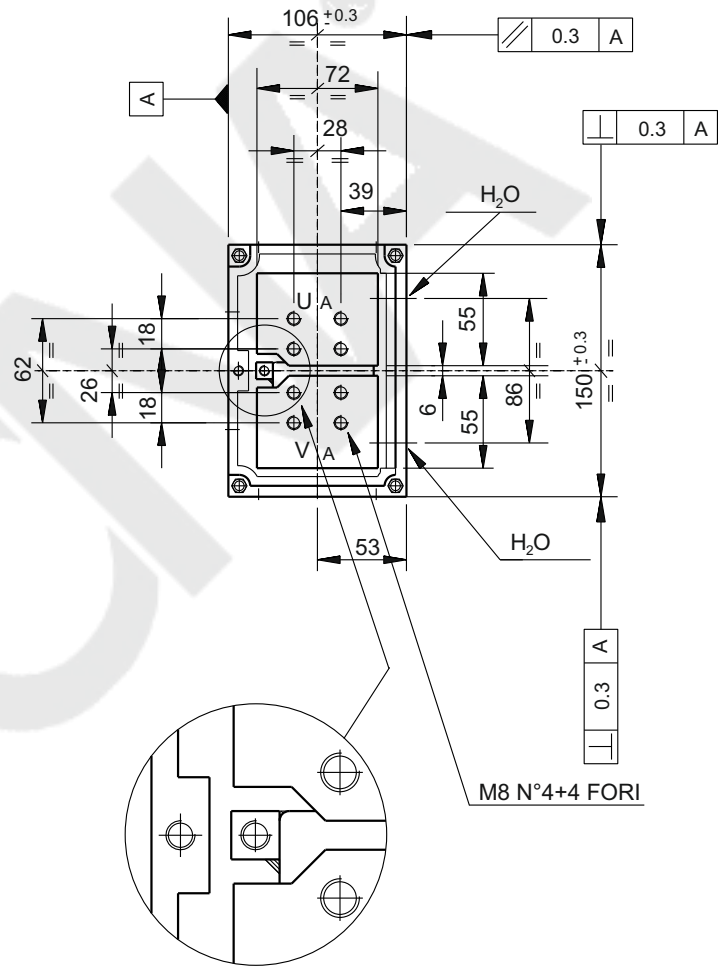
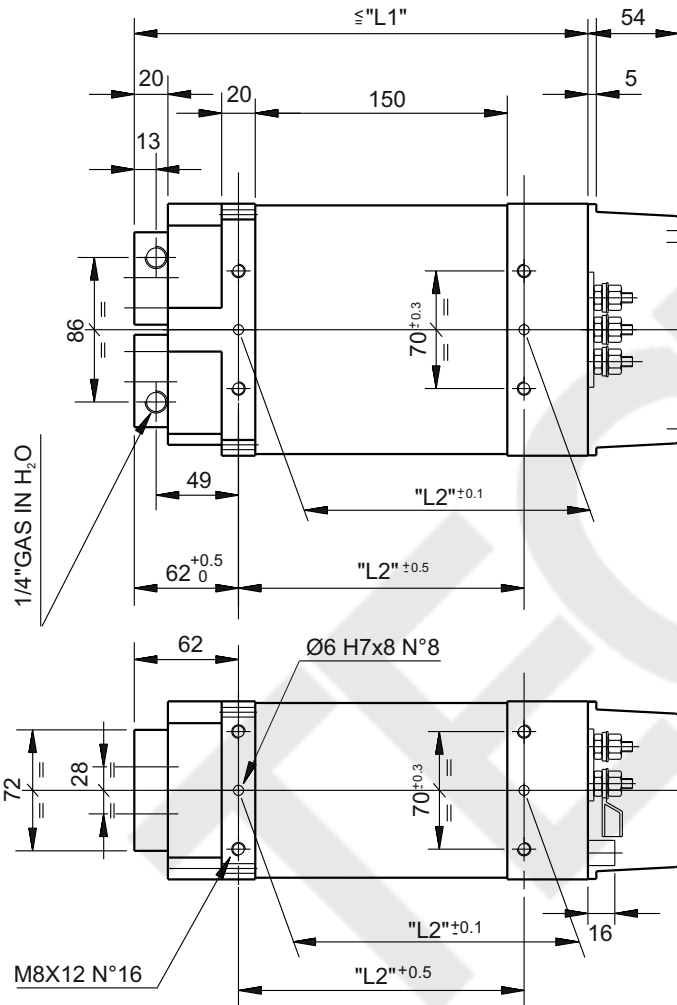

ITEM	kVA	U./Freq Volt/Hz	I ₁ 100%				V ₂₀ Volt				I ₂ 100% kA	Vcc %	H ₂ O l/min	L1	L2	D	PG	COLOR	kg	ISO
			A	1	2	3	4	1	2	3										
32778	36	*400/50	63	6,6	-	-	-	3,9	-	4	300	200	M6	21	RAL 6011	26	-			
32717	32	*400/50	56	5,9	-	-	-	3,9	-	4	270	170	M6	21	RAL 6011	23	-			

* Different voltages and frequencies on request.

TECNA S.p.A. Specifications subject to change without notice.

TECNA®

SINGLE-PHASE TRANSFORMERS

ISO 5826 63 ÷ 100 kVA

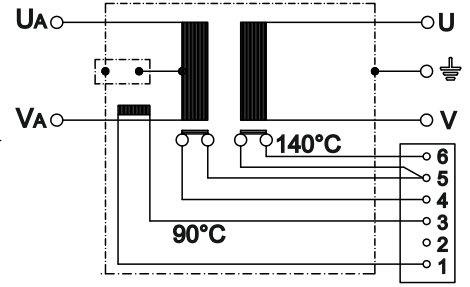
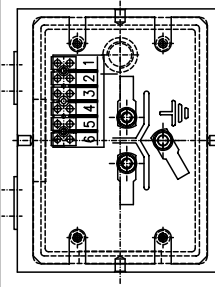
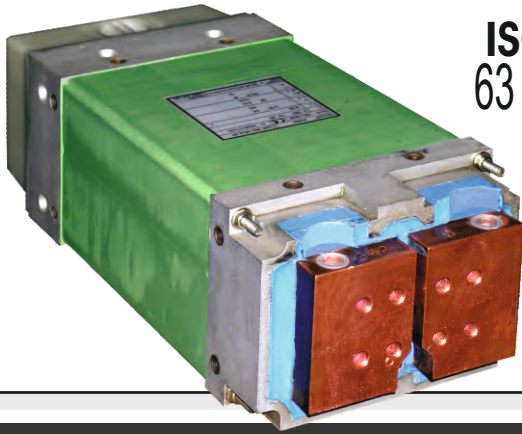

○ ○ SECONDARIO ISOLATO

○ — SECONDARIO A MASSA ⚡

CONNESS.	DESCRIZIONE CONNESS.
1-3	V=150mV/kA/1000ohm
4-5	TERMOSTATO 90°C
5-6	TERMOSTATO 140°C
4-6	TERMOSTATI N.C.

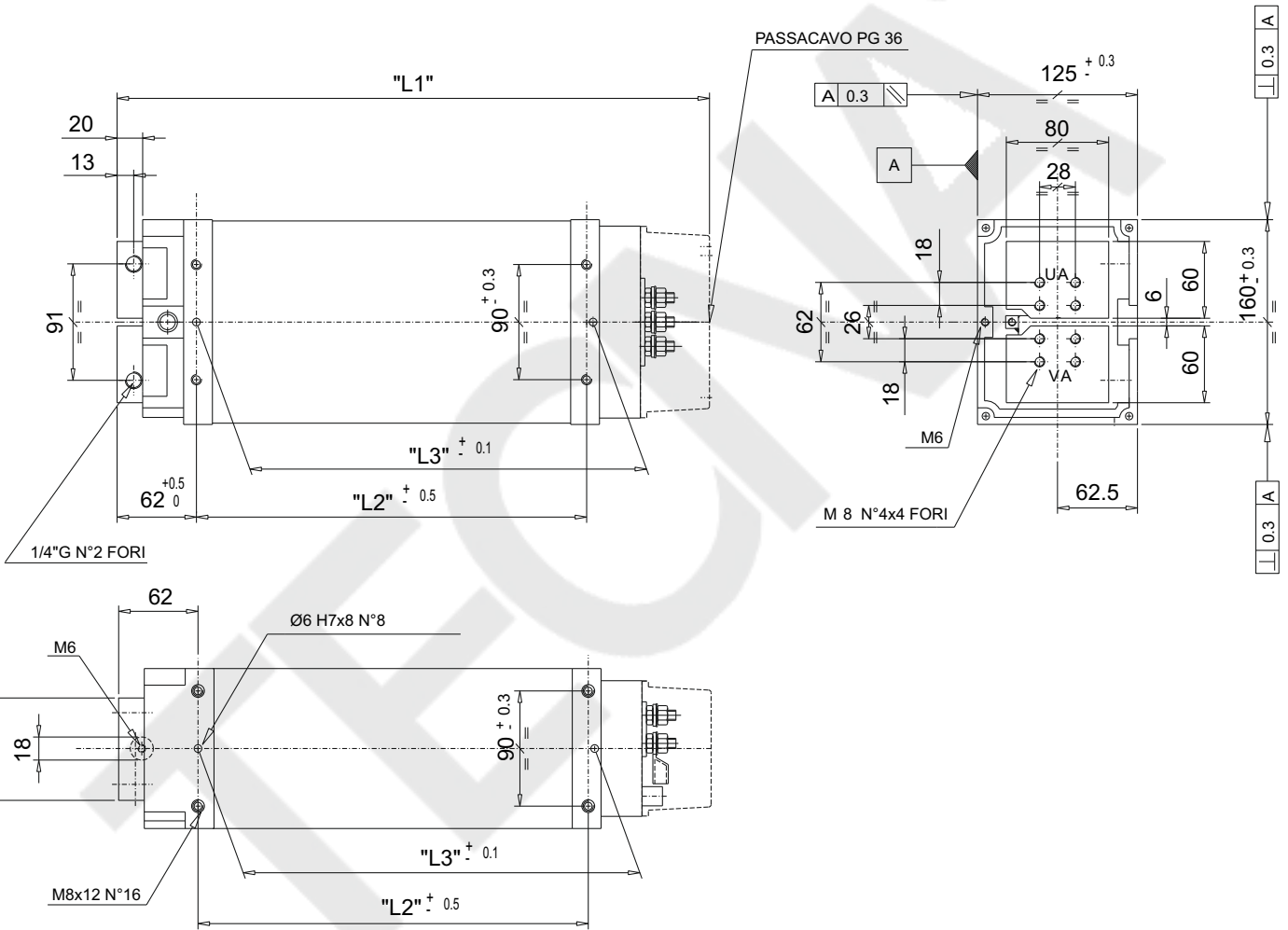

ITEM	kVA	U ₁ /Freq Volt/Hz	I ₁ 100% A	V ₂₀ Volt				I ₂ 100% kA	Vcc %	H ₂ O l/min	COLOR				kg	ISO	
				1	2	3	4				L1	L2	L3	PG			
32696	100	*400/50	-	13.5	-	-	-	5.2	-	4	496	345	-	-	-	54	-
32695	63	*400/50	111.4	10.6	-	-	-	4.2	-	4	463	305	310	21/36	RAL 6011	49	-

* Different voltages and frequencies on request.

TECNA S.p.A. Specifications subject to change without notice.

TECNA®

SINGLE-PHASE TRANSFORMERS

ISO 5826 20 ÷ 30 kVA

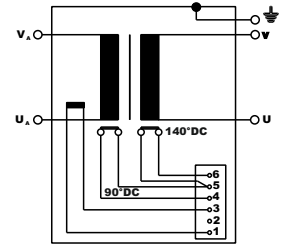
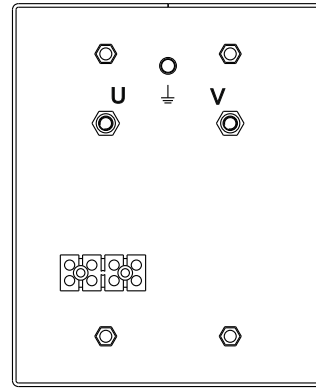

CONNESS.	DESCRIZIONE CONNESS.
1-3	V=150mV/kA/1000ohm
4-5	TERMOSTATO 90°C
5-6	TERMOSTATO 140°C
4-6	TERMOSTATI N.C.

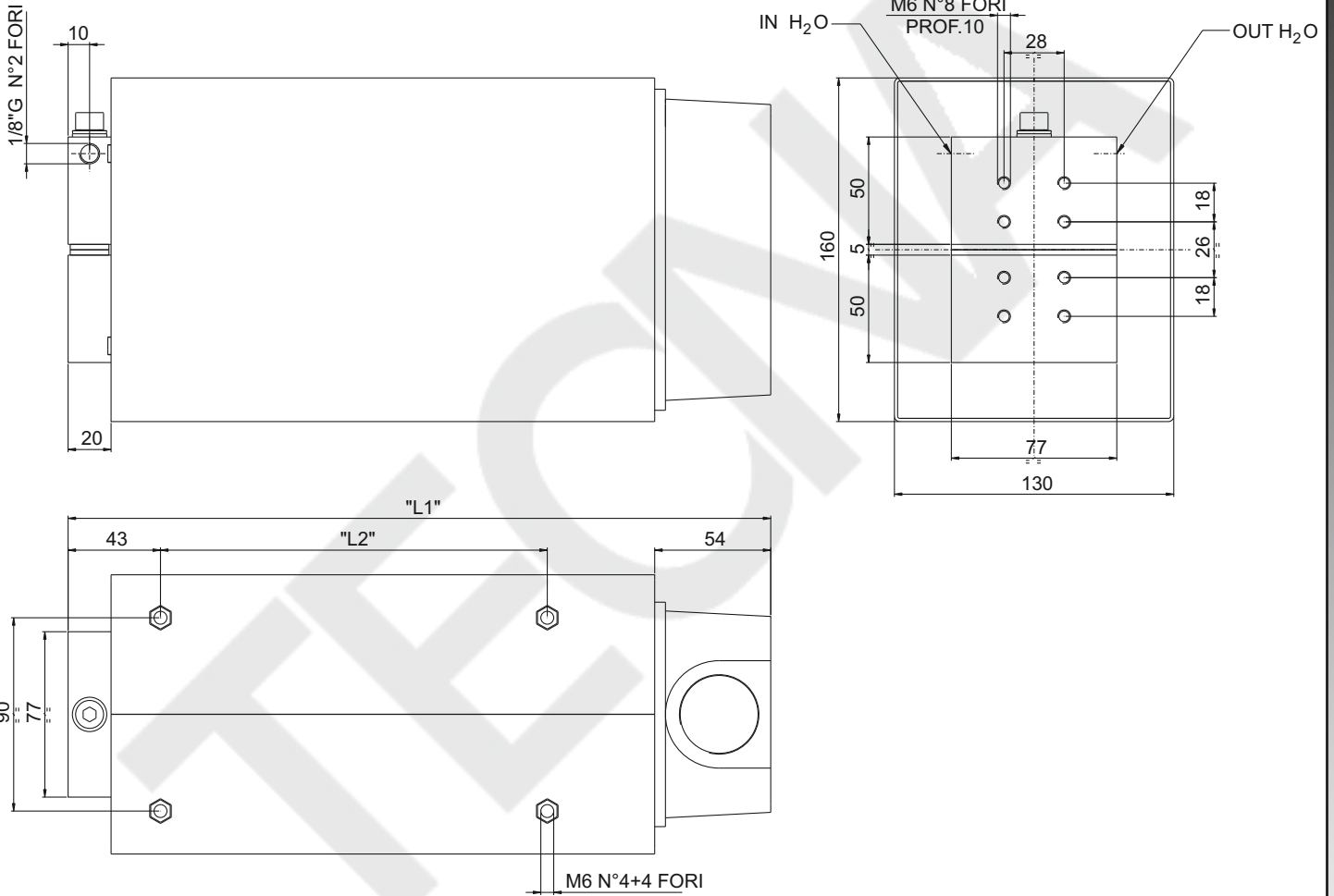

ITEM	kVA	U ₁ /Freq Volt/Hz	I ₁ 100% A	V ₂₀ Volt				I ₂ 100% kA	Vcc %	H ₂ O l/min	L1	L2	D	PG	COLORE	kg	ISO
				1	2	3	4										
36952	30	*400/50	53	4.65	-	-	-	4.56	-	4	385	245	-	-	ZINCATO - GALVANIZED GALVANISE - GALVANIZADO GALVANISIERT	40	-
36951	25	*400/50	44	4	-	-	-	4.43	-	4	352	208	-	-	ZINCATO - GALVANIZED GALVANISE - GALVANIZADO GALVANISIERT	35	-
36950	20	*400/50	35.4	3.4	-	-	-	4.17	-	4	329	180	-	-	ZINCATO - GALVANIZED GALVANISE - GALVANIZADO GALVANISIERT	27	-

* Different voltages and frequencies on request.

TECNA S.p.A. Specifications subject to change without notice.

TECNA®

SINGLE-PHASE TRANSFORMERS

ISO 5826 32 ÷ 63 kVA

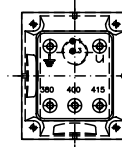

CONNEX.	DESCRIZIONE CONNEX.
1-3	V=150mV/kA/1000ohm
4-5	TERMOSTATO 90°C
5-6	TERMOSTATO 140°C
4-6	TERMOSTATI N.C.

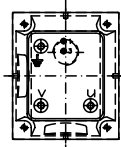

32 kVA

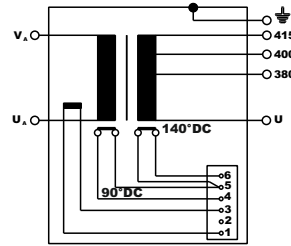

40 kVA

50 kVA - 63 kVA

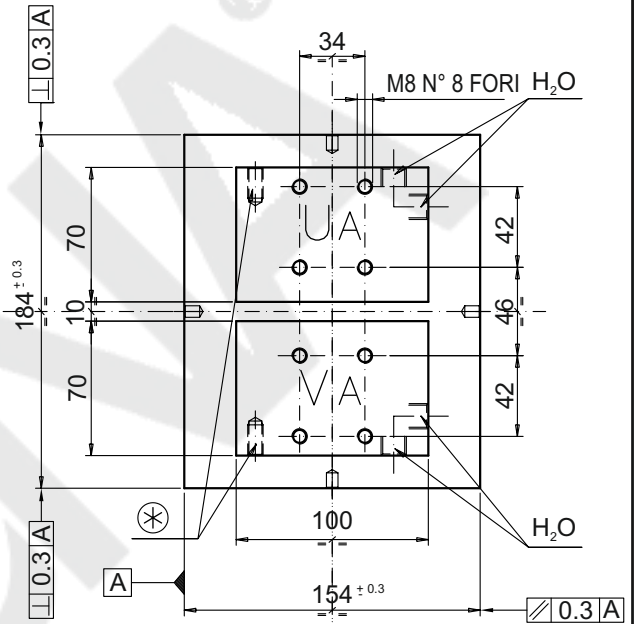
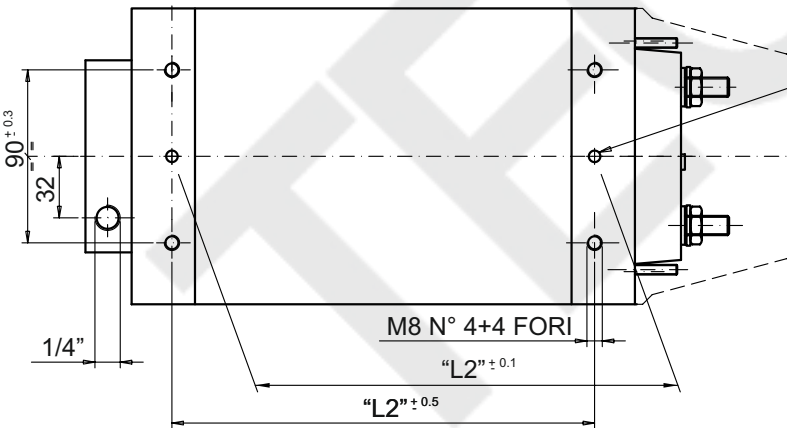
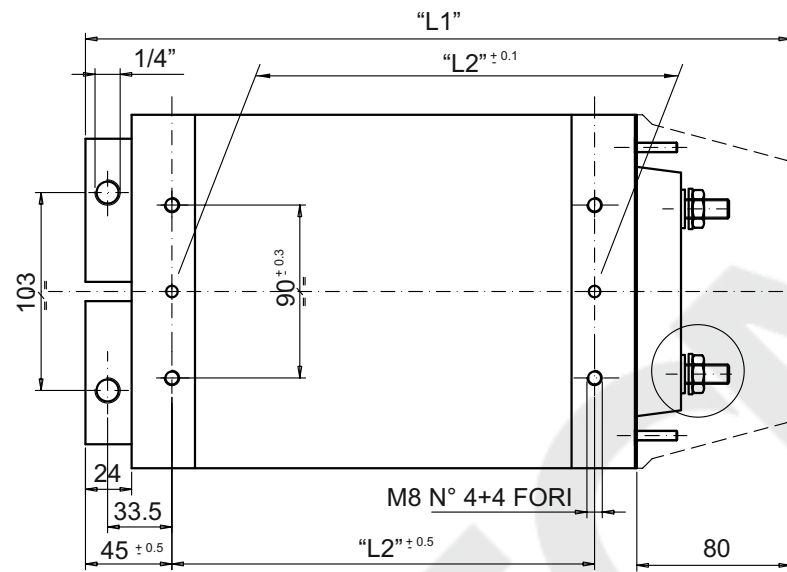
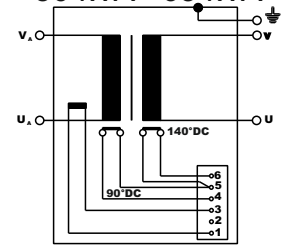

ITEM	kVA	U ₁ /Freq Volt/Hz	I ₁ 100% A	V ₂₀ Volt				I ₂ 100% kA	Vcc %	H ₂ O l/min	L1	L2	D	PG	COLOR	ISO
				1	2	3	4									
32283	63	*400/50	117,2	7,2	-	-	-	6,3	-	4	487	340	M10	36	ZINCATO - GALVANIZED GALVANISÉ - GALVANIZADO GALVANISIERT	73
31958	50	*400/50	88,4	5,2	-	-	-	6,8	-	4	402	255	M10	36	ZINCATO - GALVANIZED GALVANISÉ - GALVANIZADO GALVANISIERT	55,4
32980	40	*400/50	74,4	4,2	-	-	-	6,7	-	4	367	220	M10	36	ZINCATO - GALVANIZED GALVANISÉ - GALVANIZADO GALVANISIERT	48,5
32301	32	*400/50	59,5	4,4	-	-	-	5,1	-	4	367	220	M10	36	ZINCATO - GALVANIZED GALVANISÉ - GALVANIZADO GALVANISIERT	48,5

* Different voltages and frequencies on request.

TECNA S.p.A. Specifications subject to change without notice.

TECNA®

SINGLE-PHASE TRANSFORMERS

ISO 5826 30 ÷ 160 kVA

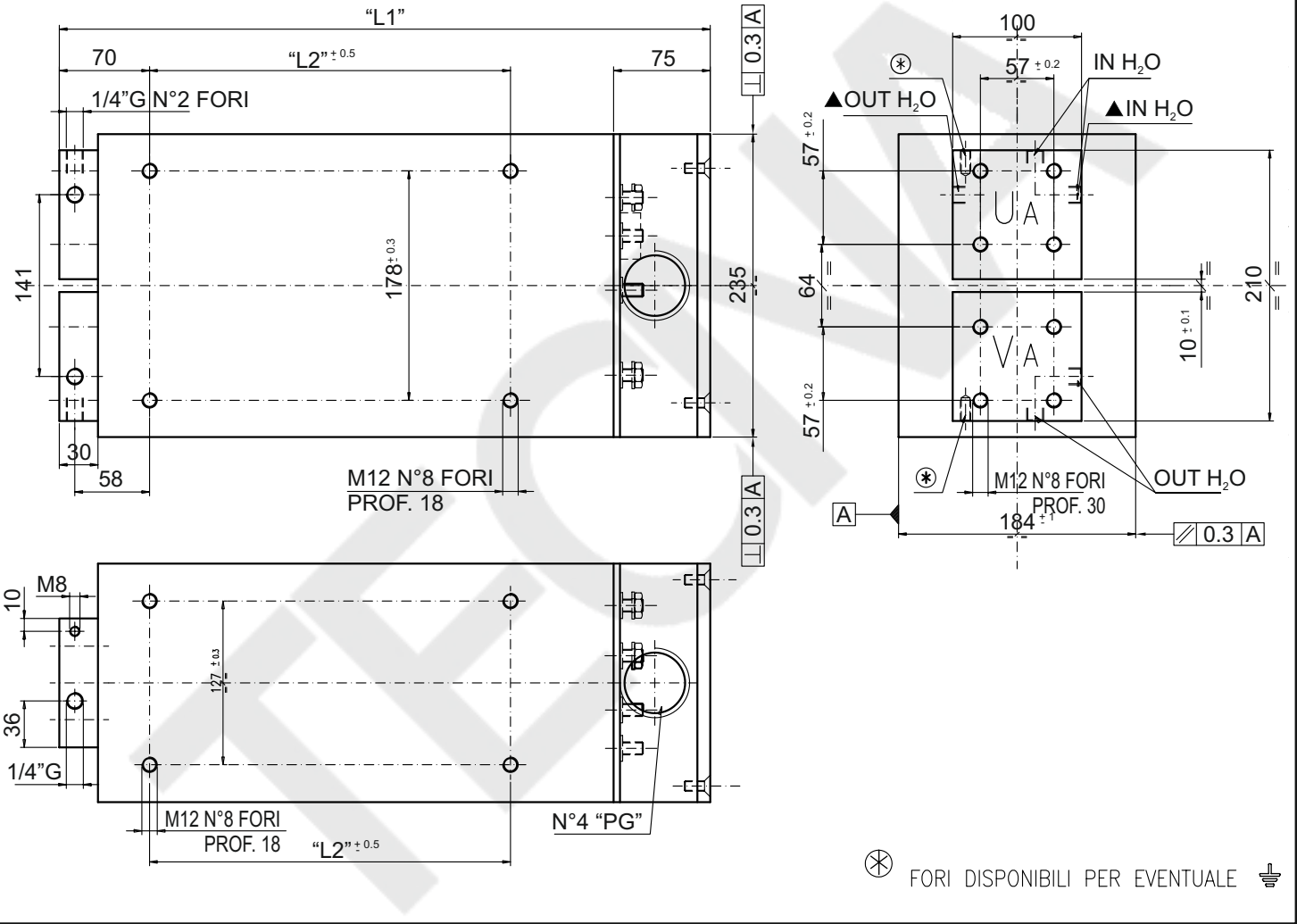
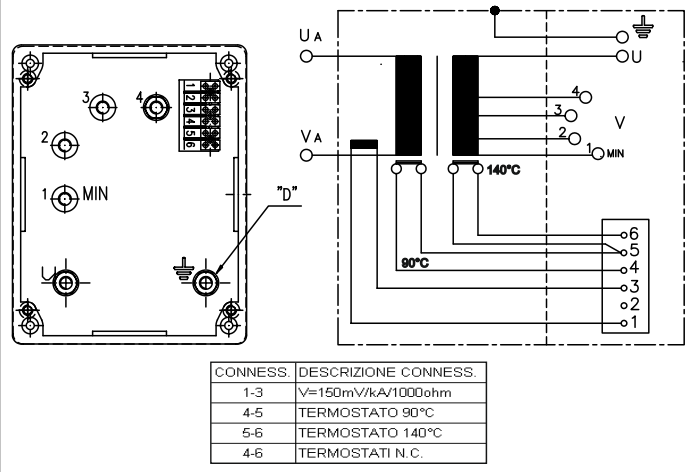
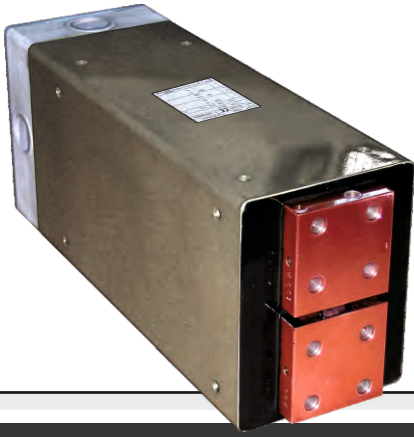

ITEM	kVA	U _i /Freq Volt/Hz	I ₁ 100% A	V ₂₀ Volt				I ₂ 100% kA	Vcc %	H ₂ O l/min	L1	L2	D	PG	COLOR	kg	ISO
				1	2	3	4										
32784	160	*400/50	282	12,1	-	-	-	9,35	-	4	655	430	M12	42	ZINCATO - GALVANIZED GALVANISÉ - GALVANIZADO GALVANISIERT	148,8	-
32835 ▲	150	*400/50	279	9,3	10,2	11,4	-	9,3	-	4	685	460	M12	42	ZINCATO - GALVANIZED GALVANISÉ - GALVANIZADO GALVANISIERT	160	-
32108 ▲	125	*400/50	220	7,4	8,1	9,1	10,5	8,4	-	4	655	430	M12	42	ZINCATO - GALVANIZED GALVANISÉ - GALVANIZADO GALVANISIERT	150	-
32305 ▲	100	*400/50	186	7,1	8	8,8	10	7,1	-	4	625	400	M10	36	ZINCATO - GALVANIZED GALVANISÉ - GALVANIZADO GALVANISIERT	140,2	-
32048 ▲	80	*400/50	149	6,1	6,76	7,52	8,31	6,8	-	4	565	340	M10	36	ZINCATO - GALVANIZED GALVANISÉ - GALVANIZADO GALVANISIERT	121,3	-
32282 ▲	63	*400/50	117	5	5,6	6,3	7,1	6,3	-	4	505	280	M10	36	ZINCATO - GALVANIZED GALVANISÉ - GALVANIZADO GALVANISIERT	101	-
33235	40	*380/50	74	3,4	3,8	4,3	4,75	6	-	4	435	225	M10	36	ZINCATO - GALVANIZED GALVANISÉ - GALVANIZADO GALVANISIERT	82	-
33410	30	*400/50	72	2,82	3,35	3,91	4,32	4,93	-	4	435	225	M10	36	ZINCATO - GALVANIZED GALVANISÉ - GALVANIZADO GALVANISIERT	81	-

* Different voltages and frequencies on request.
▲ Cooling water system amended.

TECNA®

SINGLE-PHASE TRANSFORMERS

ISO 5826 63 ÷ 100 kVA

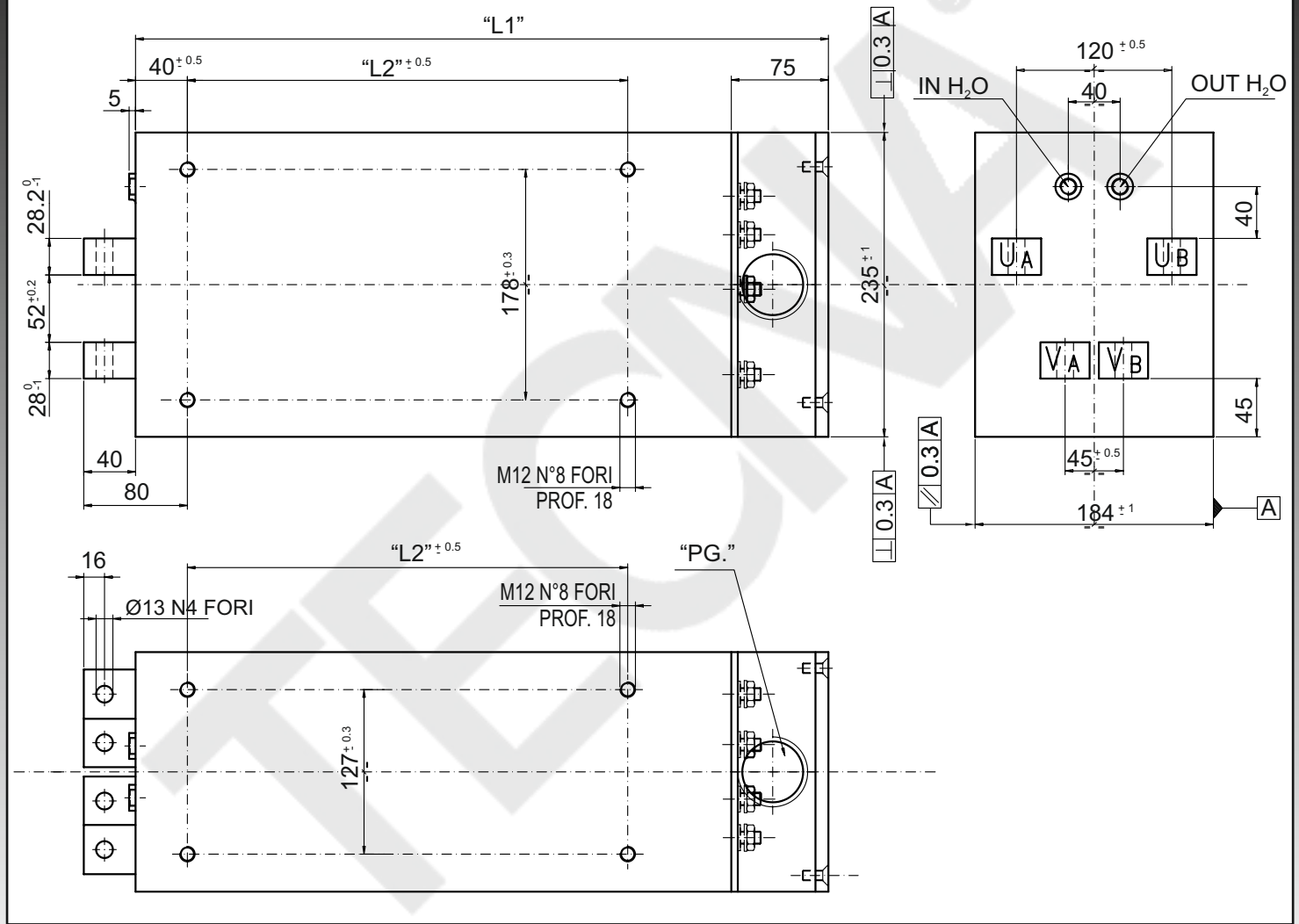
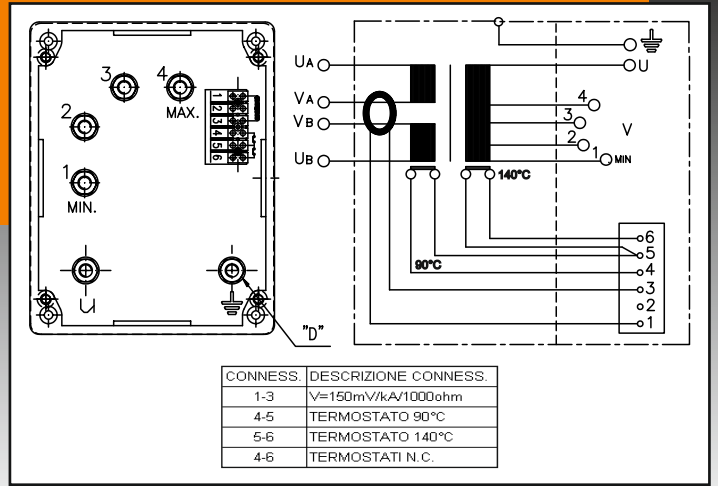

ITEM	kVA	U ₁ /Freq Volt/Hz	I ₁ 100% A	V ₂₀ Volt				I ₂ 100% kA	Vcc %	H ₂ O l/min	L1	L2	D	PG	COLOR	kg	ISO
				1	2	3	4										
31823	100	*380/50	186	7,1	8	9	10	3,53+3,53	-	4	535	340	M10	36	ZINCATO - GALVANIZED GALVANISÉ - GALVANIZADO GALVANISIERT	135	7284
32863	63	*400/50	117	5	5,6	6,3	7,1	3,15+3,15	-	4	475	280	M10	36	ZINCATO - GALVANIZED GALVANISÉ - GALVANIZADO GALVANISIERT	99	7284

* Different voltages and frequencies on request.

TECNA S.p.A. Specifications subject to change without notice.

TECNA®

SINGLE-PHASE TRANSFORMERS

ISO 5826 150 ÷ 290 kVA

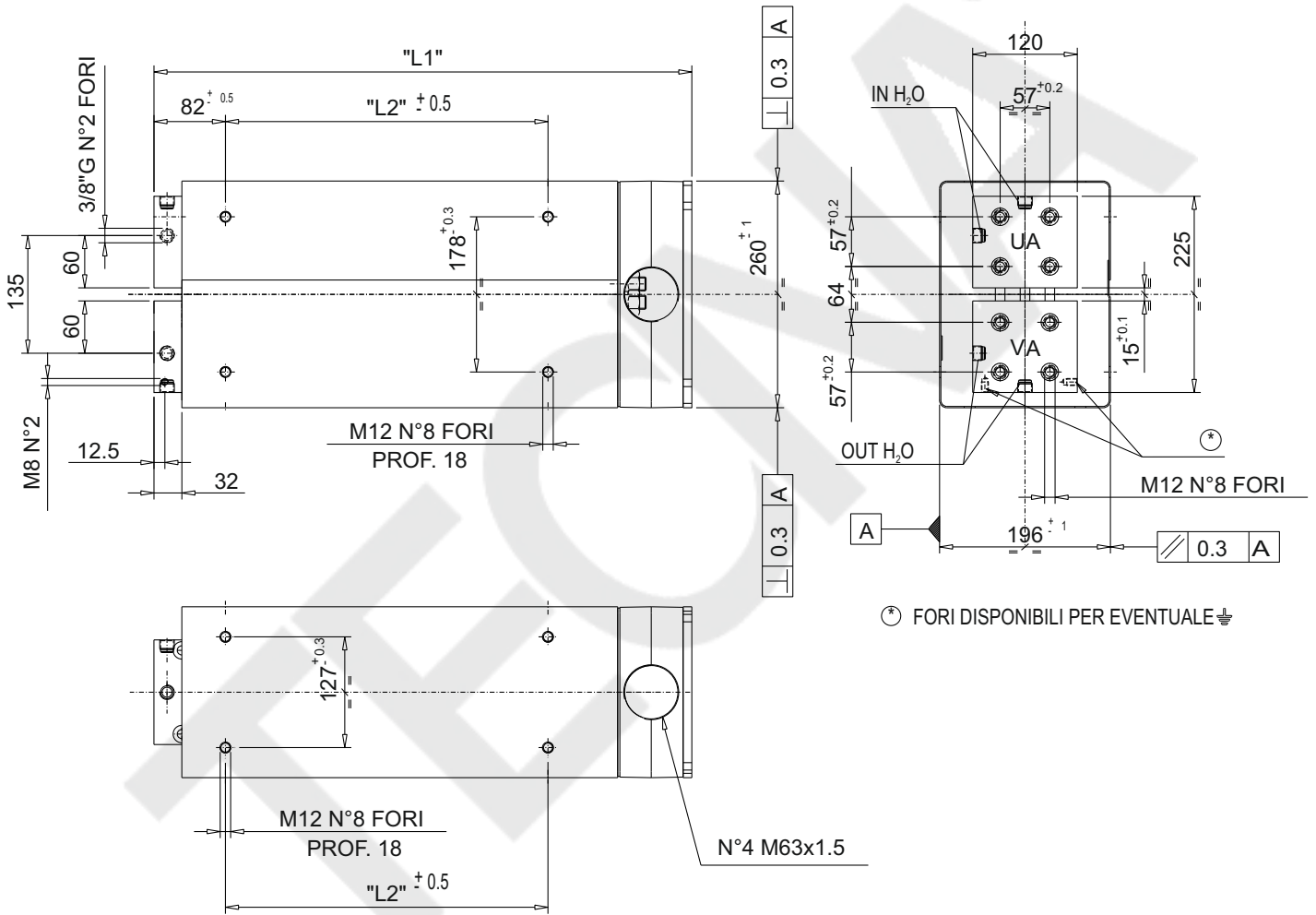
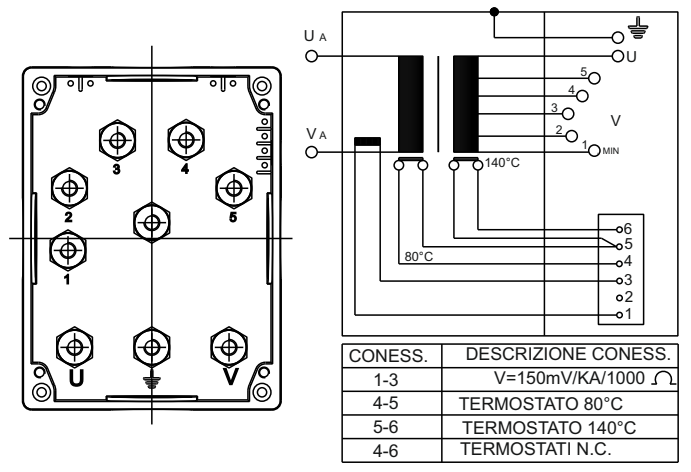
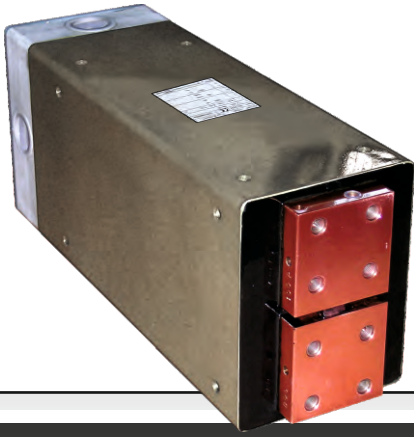

ITEM	kVA	U _i /Freq Volt/Hz	I ₁ 100% A	V ₂₀ Volt				I ₂ 100% kA	Vcc %	H ₂ O l/min	L1	L2	D	PG	COLOR	kg	ISO
				1	2	3	4										
36599F	290	*400/50	512	12.1	13.3	14.2	15.2	17.5	-	6	787	540	M10	36	ZINCATO - GALVANIZED GALVANISE - GALVANIZADO GALVANISIERT	-	7284
36598F	200	*400/50	344	9.1	10	10.7	11.6	12	-	6	687	440	M10	36	ZINCATO - GALVANIZED GALVANISE - GALVANIZADO GALVANISIERT	-	7284
36597F	150	*400/50	265	6.89	7.27	8	8.51	11.4	6.4	4.5	617	532	M10	36	ZINCATO - GALVANIZED GALVANISE - GALVANIZADO GALVANISIERT	148.5	7284

* Different voltages and frequencies on request.

TECNA S.p.A. Specifications subject to change without notice.

TECNA®

SINGLE-PHASE
TRANSFORMERS

ISO 5826
100 ÷ 315 kVA

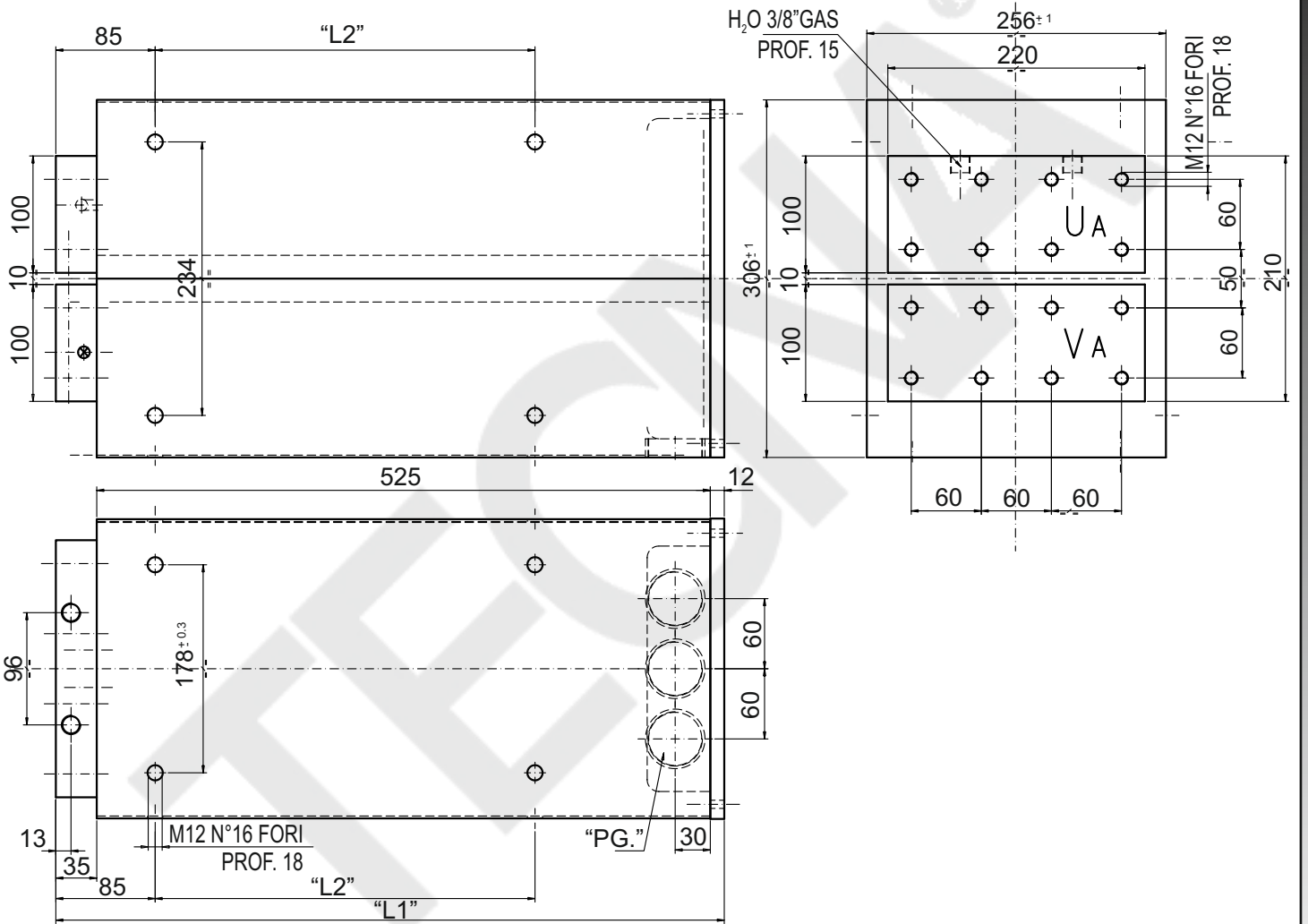
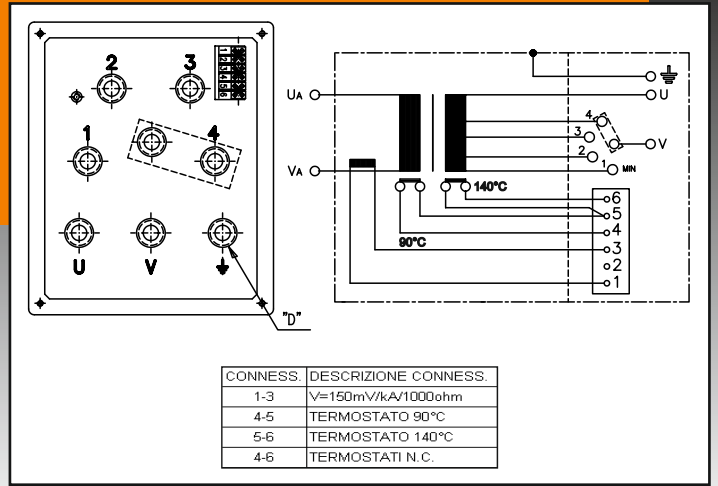

ITEM	kVA	U ₁ /Freq Volt/Hz	I ₁ 100% A	V ₂₀ Volt				I ₂ 100% kA	Vcc %	H ₂ O l/min	L1	L2	D	PG	COLOR	kg	ISO
				1	2	3	4										
33518	315	*400/50	556,8	10	11,1	12,5	13,7	16,14	7,2	6	682	400	M16	36	ZINCATO - GALVANIZED GALVANISE - GALVANIZADO GALVANISIERT	283,4	-
33415	250	*400/50	442	8,9	10	11,1	12,5	14,2	5,4	6	637	340	M16	36	ZINCATO - GALVANIZED GALVANISE - GALVANIZADO GALVANISIERT	260	-
33517	200	*400/50	353,5	8	8,9	10	11,1	12,7	5,4	6	612	280	M12	36	ZINCATO - GALVANIZED GALVANISE - GALVANIZADO GALVANISIERT	246	-
33498	160	*400/50	282,8	7,14	8	9,1	10	11,3	5,5	6	572	225	M12	36	ZINCATO - GALVANIZED GALVANISE - GALVANIZADO GALVANISIERT	221	-
32997	100	*380/50	282,8	4	4,8	5,75	-	12,5	-	6	482	235	M12	36	ZINCATO - GALVANIZED GALVANISE - GALVANIZADO GALVANISIERT	172	-

* Different voltages and frequencies on request.

TECNA S.p.A. Specifications subject to change without notice.

TECNA®

SINGLE-PHASE TRANSFORMERS

ISO 5826 45 ÷ 100 kVA

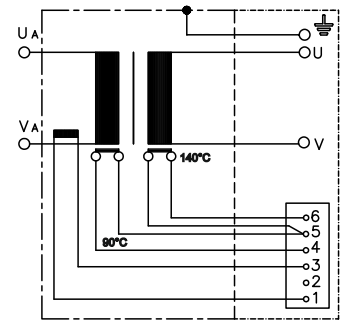
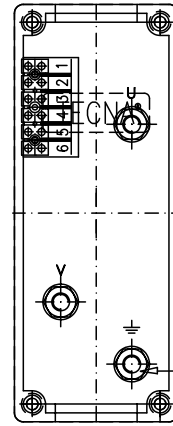

CONNEX.	DESCRIZIONE CONNESS.
1-3	V=150mV/kA/1000ohm
4-5	TERMOSTATO 90°C
5-6	TERMOSTATO 140°C
4-6	TERMOSTATI N.C.

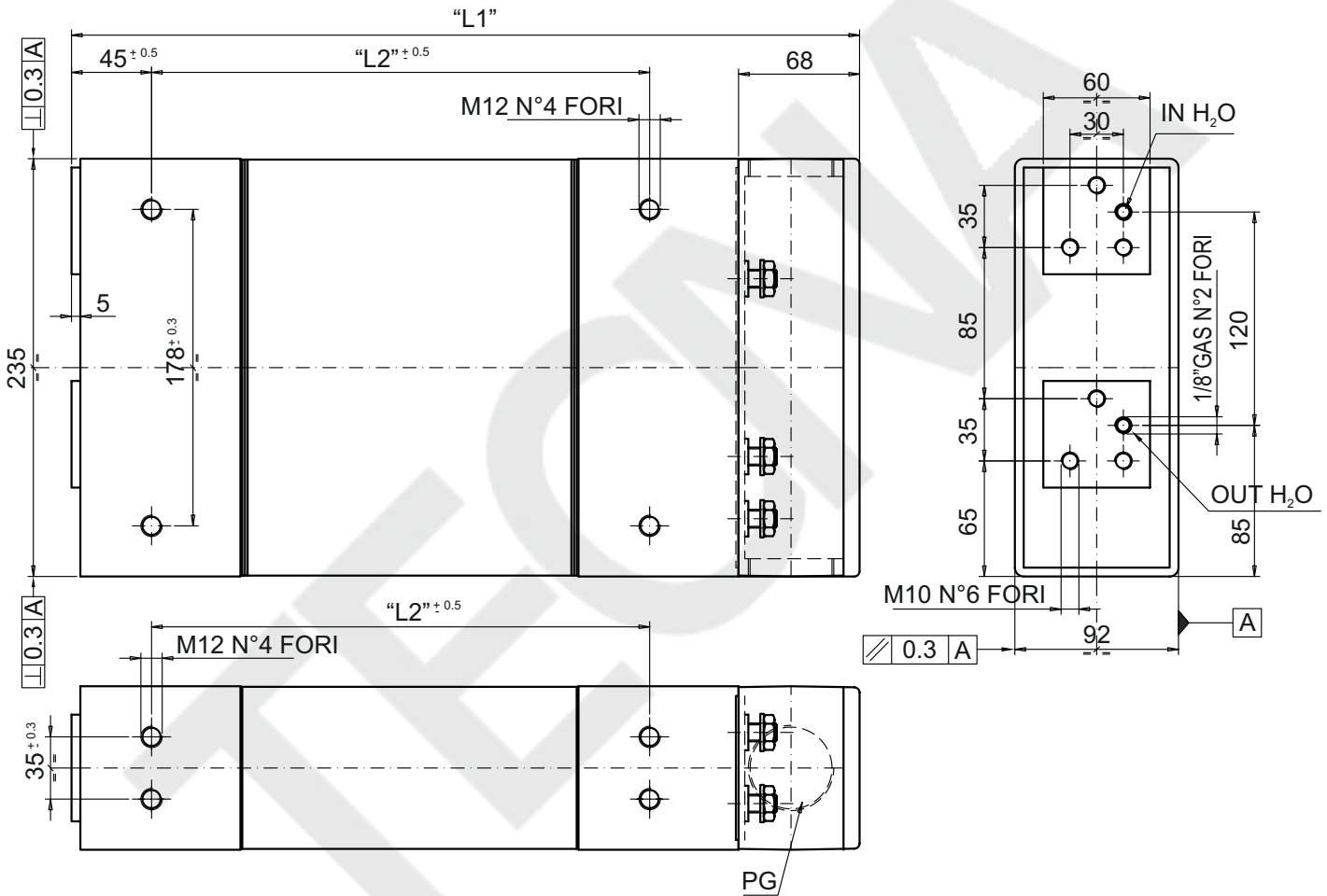

ITEM	kVA	U ₁ /Freq Volt/Hz	I ₁ 100% A	V ₂₀ Volt				I ₂ 100% kA	Vcc %	H ₂ O l/min	L1	L2	D	PG	COLOR	ISO kg
				1	2	3	4									
33413	100	*400/50	176,7	10	-	-	-	7,07	8,6	4	678	515	M10	36	RAL 6011	78,5
32725	63	*380/400/50	186	7,1	-	-	-	6,3	10,2	4	578	515	M10	36	RAL 6011	78
32633	45	*380/50	83	5,28	-	-	-	6	9,2	4	483	320	M10	36	RAL 6011	47,6

* Different voltages and frequencies on request.

TECNA S.p.A. Specifications subject to change without notice.

TECNA®

SINGLE-PHASE TRANSFORMERS

ISO 5826 45 ÷ 100 kVA

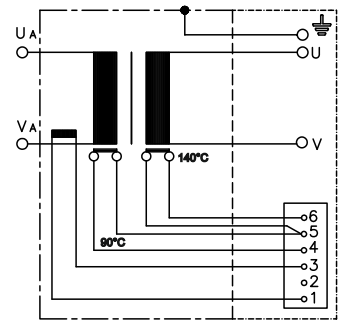
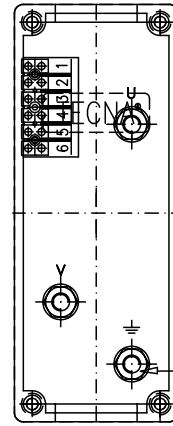

CONNESS.	DESCRIZIONE CONNESS.
1-3	V=150mV/kA/1000ohm
4-5	TERMOSTATO 90°C
5-6	TERMOSTATO 140°C
4-6	TERMOSTATI N. C.

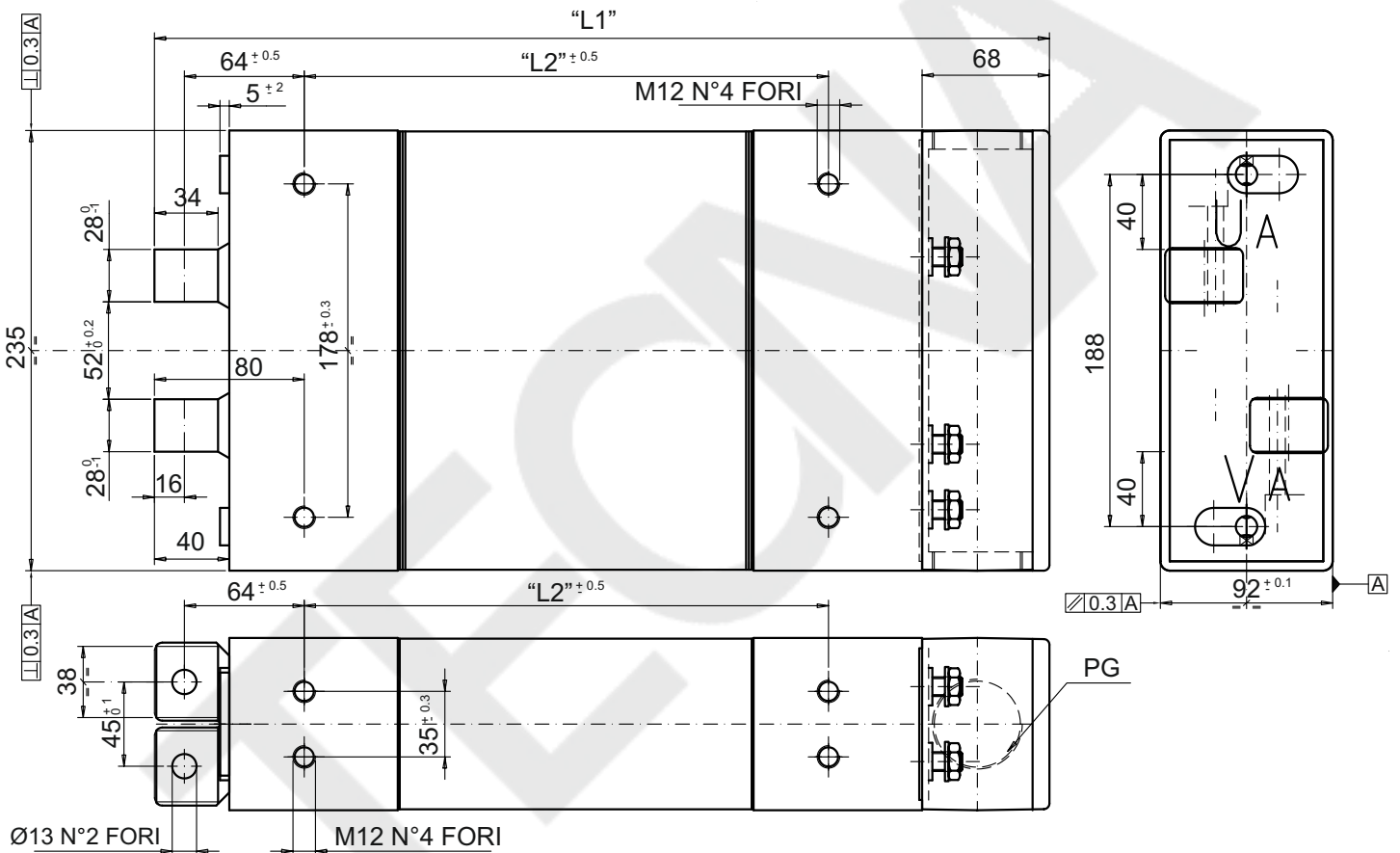

ITEM	kVA	U ₁ /Freq Volt/Hz	I ₁ 100% A	V ₂₀ Volt				I ₂ 100% kA	Vcc %	H ₂ O l/min	L1	L2	D	PG	COLOR	kg	ISO
				1	2	3	4										
39893	100	*380/50	186	10	-	-	-	7,07	9,4	4	793	630	M10	36	RAL 6011	78,4	-
40195	63	*380/50	117	10	-	-	-	4,45	10,5	4	678	515	M10	36	RAL 6011	78	-
32951	45	*380/50	83	5,3	-	-	-	6	11	4	483	320	M10	36	RAL 6011	48	-

* Different voltages and frequencies on request.

TECNA S.p.A. Specifications subject to change without notice.

TECNA®

SINGLE-PHASE TRANSFORMERS

ISO 5826 32 ÷ 100 kVA

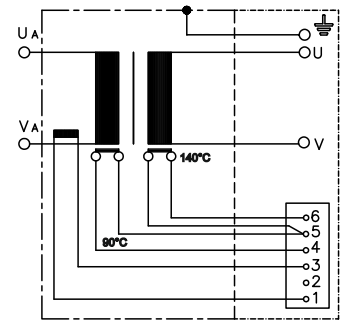
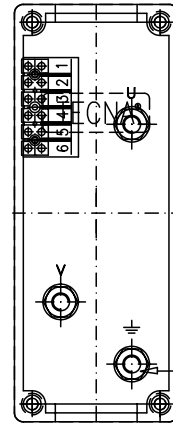
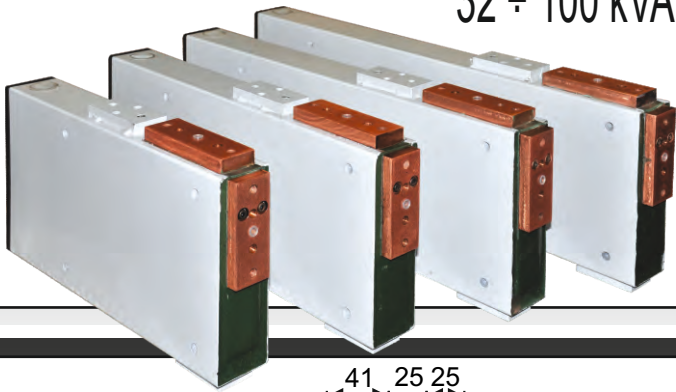

CONNESS.	DESCRIZIONE CONNESS.
1-3	V=150mV/kA/1000ohm
4-5	TERMOSTATO 90°C
5-6	TERMOSTATO 140°C
4-6	TERMOSTATI N. C.

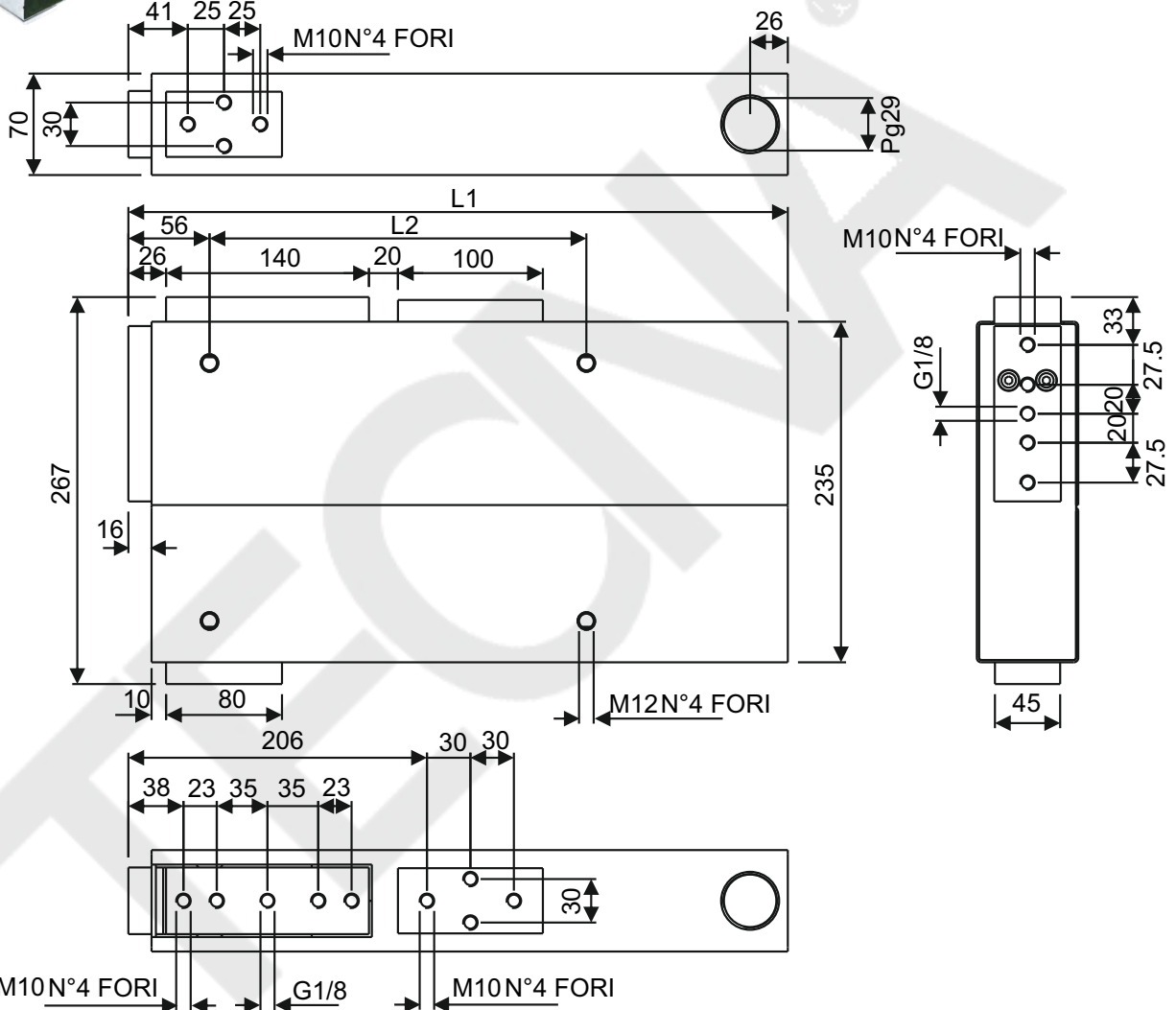

ITEM	kVA	U _i /Freq Volt/Hz	I ₁ 100% A	V ₂₀ Volt				I ₂ 100% kA	Vcc %	H ₂ O l/min	L1	L2	D	PG	COLOR	kg	ISO
				1	2	3	4										
35391	100	*400/50	-	8,00	-	-	-	8,80	-	4	755	560	M10	29	ZINCATO - GALVANIZED GALVANISE - GALVANIZADO GALVANISIERT	67,5	5826
41073	63	*400/50	-	6,45	-	-	-	6,90	-	4	655	460	M10	29	ZINCATO - GALVANIZED GALVANISE - GALVANIZADO GALVANISIERT	57	5826
41074	45	*400/50	-	4,65	-	-	-	6,84	-	4	555	360	M10	29	ZINCATO - GALVANIZED GALVANISE - GALVANIZADO GALVANISIERT	47	5826
41075	32	*400/50	-	3,05	-	-	-	7,37	-	4	455	260	M10	29	ZINCATO - GALVANIZED GALVANISE - GALVANIZADO GALVANISIERT	36	5826

* Different voltages and frequencies on request.

TECNA S.p.A. Specifications subject to change without notice.



Sono a disposizione anche una serie di trasformatori trifase a corrente continua.

ITEM	kVA 50%	U ₁ /Freq Volt/Hz
70720	630	*380/50
71640	480	*380/50
71428	400	*380/50
71427	250	*400/50
71426	160	*400/50
71429	100	*400/50

* Different voltages and frequencies on request.

TECNA S.p.A. Specifications subject to change without notice.



ALATISTHERM d.o.o

Koče Kapetana 25 , 35230 Čuprija , Srbija
tel/fax : +381 (0) 35 8471-196
mob1/2 : +381 (0) 65 2771-802 / +381 (0) 65 8410-651

ITEM	kVA 20%	kVA 50%	U ₁ /Freq Volt/Hz	V ₂₀ Volt				I ₂ 100% kA	Vcc %	H ₂ O l/min	COLOR	kg	ISO
				1	2	3	4						
41930	1050	664	500/1000	12,7	-	-	-	36,7	-	24	INOX	250	-
40266	379	240	500/1000	10,9	-	-	-	15,5	-	15	INOX	85	-
40314	284	180	500/1000	10,3	-	-	-	12,3	-	12	INOX	64	-
37610	251	160	500/1000	12,3	-	-	-	9,2	-	8	INOX	32	-
40139	141	90	500/1000	9,9	-	-	-	6,4	-	6	INOX	27	-
40138	88	56	500/1000	8,4	-	-	-	4,8	-	6	INOX	20	-
43737	80,6	51	500/1000	6,1	-	-	-	5,4	-	4	INOX	12	-
40365	52,2	33	500/1000	4,8	-	-	-	4,5	-	4	INOX	13	-

* Different voltages and frequencies on request.

TECNA S.p.A. Specifications subject to change without notice.